



PROVISIONAL
DutymAx (MS) Motor
BROCHURE

Introducing the DutymAx motor

Years of experience of designing specialised brushless motors for Defence applications, Aerospace and Space Satellites instrumentation has been focused on the demands of the industrial controls and servo drives, these motors are now available as a standalone component. Similarly, the feedback device, resolver, owes much to the heritage of the company and its skills in the design and manufacture of rotating components. The company is now offering to system builders worldwide, this range of components based on high quality and sophisticated design, coupled with ISO9001 quality assured manufacture.

The DutymAx MS servo motors have excellent power to size ratio giving optimal dynamic response. This is provided by a superior design of magnetic circuit within the motor, using high energy rare earth magnets, and a low inertia laminated rotor and a high slot fill stator.

The shaft resolver is mounted directly onto the motor offering a robust and accurate measuring system for speed and position signals to suit most drives and control system requirements.

The motors are available in four frame sizes, 75, 95, 115 and 142 mm square body.

The DutymAx MS range of motors are a 200-240Volt rms, 6 pole, permanent magnet motor exhibiting a sinusoidal back EMF characteristic.

Standard Features

- Modular rotor design.
- Rotor assembly balanced to ISO1940 (BS 6861) G 6.3.
- Class H insulation.
- High thermal dissipation.
- Thermal overload protection.
- Rear shaft extension.
- Front shaft lip-seal up to 3,000rpm.
- Connectors for Power and signal.
- High output for size and weight.
- IEC mounting flange.
- Shaft key as standard.
- 75-142 motors have 6 pole = 3 pole pairs

Optional Features

- Hybrid box and Terminal box available.
- Parking brake with no increase in length, retro-fit table at factory.
- High inertia.

Optional Products

- Cable assemblies for power, signal and brake.

Motor Specification

Physical		Environmental	
Insulation class	Class H BS EN60034-1		
Rotational accuracy	IEC60072-1 Class N	Operating Temperature	0°C to 40°C ambient
Degree of balance	Rotor is balanced to ISO 1940 or (BS6861) G 6.3	Storage Temperature	-20°C to 70°C
Shaft extension	Dimension to IEC60072 -1, key and keyway to IEC60072-1	Temperature rise	125°C over ambient of 40°C Max
Temperature monitoring	PTC thermistor, 160°C switch temperature	Relative Humidity	90% Non condensing
Connections	Separate connectors or cable input glands for motor, resolver and thermistor, brake.		

Resolver Specification

DRG No	UNITS	34489/03
TYPE No		55RSS116P
VOLTAGE	VOLTS.	6
FREQUENCY	KHz.	7.5
PRIMARY		ROTOR
No OF POLES		2
TRANSFORMATION RATIO		0.28 ± 10%
PHASE SHIFT	DEG NOM.	-1
PRIMARY CURRENT	mA NOM.	55
INPUT POWER	mW NOM.	150
ELECTRICAL ERROR	Mins MAX.	± 20
TOTAL NULL VOLTS	mV MAX.	20
Z RO	OHMS NOM.	75+j105
Z SO	OHMS NOM.	36+j68
Z SS	OHMS NOM.	31+j60
D.C RESISTANCE (EXCITATION)	OHMS.	35
D.C RESISTANCE (STATOR)	OHMS.	11
TEMPERATURE RANGE	DEG C NOM.	-55 TO +155
INERTIA	gcm ²	198
LEAD LENGTH	Mm MIN.	380
SHAFT		15.011/15.000

Brake Specification

Motor Frame	Static Torque	Supply Volts	Input Power	Current	Moment of Inertia	Weight
Size	Nm	V d.c.	Watts	A	kgm ² x 10 ⁻⁶	kg
75	2	24	14	0.58	3.0	0.4
95	6	24	30	1.25	29	0.5
115	12	24	30	1.25	49	0.9
142	20	24	30	1.25	128.0	2.25

- The brakes are intended for parking duty and engage on power de-energisation.
- Refer to drive centre if your application requires dynamic braking in emergency conditions.
- To provide protection to the brake control circuit it is recommended that a diode is connected across the output terminals of the solid state or relay contacts devices. Ask for detailed information.
- Motor length is identical with or without brake.

Ordering Information

Use the information below in the illustration to create an order code for a DutymAx MS motor. The details in the band are an example of an order reference.

ORDER REFERENCE EXAMPLE

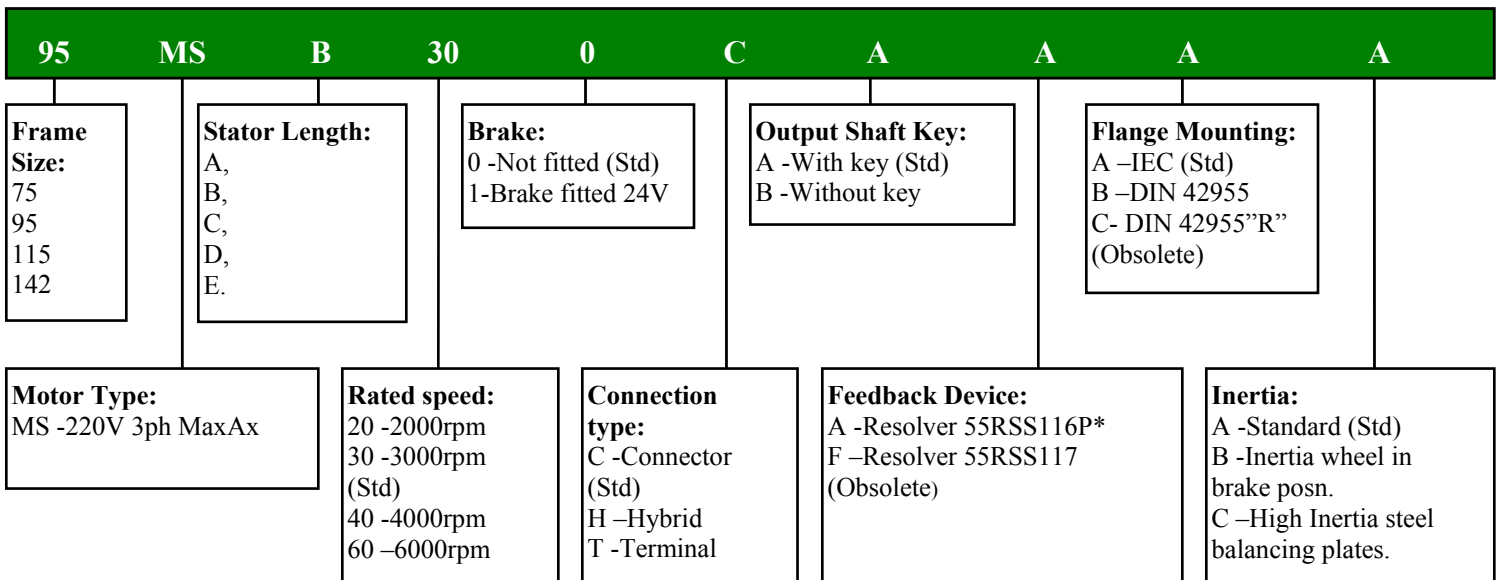

*55RSS116P replaced the 55RSS117

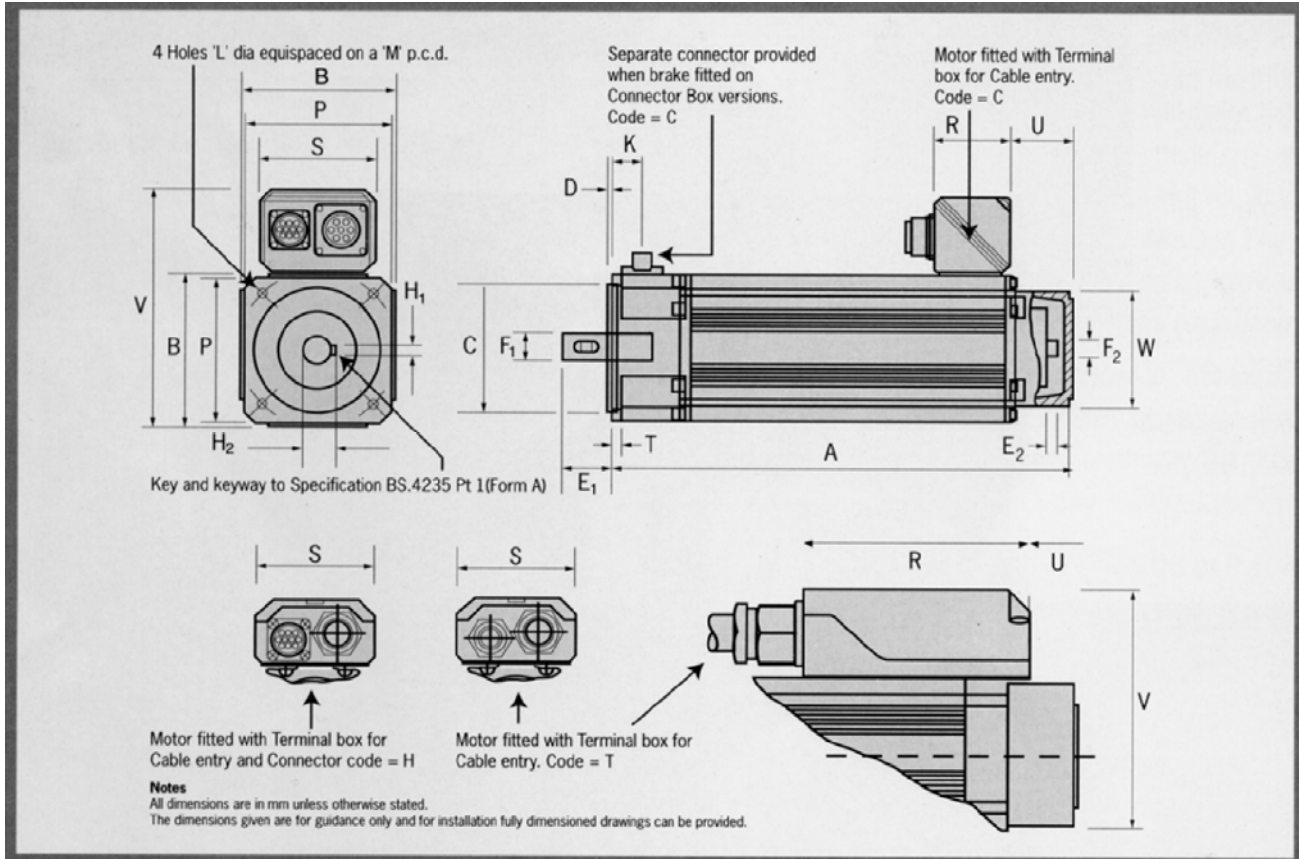
Dimensions

Frame Size	75MS					95MS					115MS					142MS				
Dimension/Length suffix	A	B	C	D	E	A	B	C	D	E	A	B	C	D	E	A	B	C	D	E
A Length Overall	225	254	283	312		235	264	293	322	351	245	274	303	332	361	275	303	332	361	390
B Body Square	75.5					95.5					115.6					143.0				
C Register Diameter	59.993/60.012					79.993/80.012					94.991/95.013					129.989/130.014				
D Register Length	2.5					3					3					3				
E1 Shaft Length (Front)	23	30		30	40		40		40	50		40		50		50		50		50
E2 Shaft Length (Rear)	10.40/11.60					10.40/11.60					10.40/11.60					10.40/11.60				
F1 Shaft Diameter (Front)	11	14		14	19		19		19	24		19		24		24		24		24
F2 Shaft Diameter (Rear)	12					12					12					12				
H1 Shaft key Width	4	5		5	6		6		6	8		6		8		8		8		8
H2 Shaft Key Height	12.5	16		16	21.5		21.5		21.5	27		21.5		27		27		27		27
K Brake Connector Location	16					16.3					14					21.5				
L Fixing Hole Diameter	5.8					7					9					11.5				
N Fixing Hole p.c.d.	75					100					115					165				
P Flange Square	70.0/70.5					92.0/92.5					105.0/105.5					142.0/143.0				
T Flange Thickness	5.8/6.2					5.8/6.2					8.8/9.2					10.8/11.0				
W Resolver Cover Diameter	71					71					71					71				
Connector Version (C)																				
R Connector Box Length	48.4					48.4					48.4					52.4				
S Connector Box Width	74					74					74					92				
U Connector Box Location	53.4					38.4					42.4					42.4				
V Overall Height	125					145					165					196				
Terminal/Hybrid Box (T/H)																				
R Connector Box Length	110					110					110					110				
S Connector Box Width	76					76					76					76				
U Connector Box Location	23.8					8.8					12.9					12.8				
V Overall Height	119					139					159					190				

Connections

Connectors

MOTOR		SIGNAL		BRAKE	
PIN	FUNCTION	PIN	FUNCTION	PIN	FUNCTION
A	U	A	Excitation high	A	0V
B	V	B	Excitation low	B	
C	W	C	Cos low	C	24V d.c.
D		D	Cos high		
E		E	Sin high		
F		F	Sin low		
G	EARTH	G			
		H			
		J	Thermistor		
		K	Thermistor		

Power connector 7way small fitted to 75 MS-95 MS motors.

Power connector 7way large fitted to 115 MS-142 MS motors.

Terminal

MOTOR			SIGNAL		
COLOUR	SOCKET	FUNCTION	COLOUR	SOCKET	FUNCTION
Red	U	U	Red/White	1	Excitation high
Orange	V	V	Black/White	2	Excitation low
Yellow	W	W	Black	3	Cos low
			Red	4	Cos high
			Blue	5	Sin high
			Yellow	6	Sin low
			(Blue)	7	Thermistor
			(Red)	8	Thermistor
				9	Brake 0V
				10	Brake 24V

Hybrid

MOTOR			SIGNAL		
COLOUR	SOCKET	FUNCTION	COLOUR	PIN	FUNCTION
Red	U	U	Red/White	A	Excitation high
Orange	V	V	Black/White	B	Excitation low
Yellow	W	W	Black	C	Cos low
			Red	D	Cos high
			Blue	E	Sin high
			Yellow	F	Sin low
				G	Brake 0V
				H	Brake 24V
			(Blue)	J	Thermistor
			(Red)	K	Thermistor

MS servo motor technical specifications

For 3 Phase VPWM Drives 200 - 240Vrms

Motors with Resolver Feedback

Δt = 125 degC

Motor Frame Size (mm)		75			95			115			142		
All Speeds	Frame Length	A	B	C	A	B	C	A	B	C	A	B	C
Continuous Stall Torque (Nm)		1.3	2.3	3.1	2.5	4.3	6.0	4.5	7.4	10.5	7.0	12.0	17.0
Peak Torque nominal (Nm)		3.9	6.9	9.3	7.5	12.9	18.0	13.5	22.2	31.5	21.0	36.0	51.0
High Inertia (kgcm ²)		1.2	1.6	2.1	3.5	4.5	5.6	9.7	12.0	14.3	21.6	28.0	34.3
Standard Inertia (kgcm ²)		0.6	1.0	1.5	1.4	2.5	3.6	3.2	5.5	7.8	7.8	14.1	20.5
Weight (kg)		3.0	3.7	4.4	5.0	6.1	7.2	6.5	8.2	9.9	10.9	13.2	15.5
Winding Thermal Time Const.(sec)		81	74	94	172	168	183	175	185	198	213	217	275
Maximum Cogging (Nm)		0.02	0.03	0.04	0.03	0.06	0.08	0.06	0.10	0.14	0.09	0.16	0.23
Rated Speed 2000 (rpm)		Kt (Nm/A) 1.40 Ke (V/krpm) 85.5											
Rated Torque (Nm)		1.2	2.0	N/A	2.2	N/A	N/A	3.6	6.3	9.0	5.9	N/A	N/A
Stall Current (A)		1.0	1.7		1.8			3.3	5.4	7.6	5.1		
Rated Power (kW)		0.25	0.48		0.48			0.77	1.42	2.05	1.42		
R (ph-ph) (Ohms)		45.8	15.3		19.4			9.09	2.83	1.51	4.28		
L (ph-ph) (mH)		98.8	43.4		59.2			47.3	20.6	13.1	33.7		
Rated Speed 3000 (rpm)		Kt (Nm/A) 0.93 Ke (V/krpm) 57.0											
Rated Torque (Nm)		1.1	2.0	2.8	2.2	3.7	5.1	3.3	6.1	9.0	5.9	10.2	14.4
Stall Current (A)		1.4	2.5	3.4	2.7	4.7	6.5	4.3	8.0	11.3	7.6	12.9	18.3
Rated Power (kW)		0.38	0.69	0.97	0.69	1.32	1.85	1.04	1.92	2.89	1.98	3.30	4.46
R (ph-ph) (Ohms)		18.9	6.26	3.50	8.03	2.68	1.57	4.01	1.30	0.73	1.90	0.59	0.31
L (ph-ph) (mH)		42.5	18.4	11.9	25.6	12.0	7.91	20.1	9.16	6.07	15.0	6.85	4.20
Rated Speed 4000 (rpm)		Kt (Nm/A) 0.72 Ke (V/krpm) 44.0											
Rated Torque (Nm)		0.8	1.8	N/A	3.7	N/A	N/A	N/A	N/A	N/A	N/A	N/A	N/A
Stall Current (A)		2.8	5.0		6.0								
Rated Power (kW)		0.46	0.80		0.84								
R (ph-ph) (Ohms)		10.2	3.39		5.15								
L (ph-ph) (mH)		24.6	10.8		15.5								
Rated Speed 6000 (rpm)		Kt (Nm/A) 0.47 Ke (V/krpm) 28.5											
Rated Torque (Nm)		0.8	1.8	N/A	N/A	N/A	N/A	N/A	N/A	N/A	N/A	N/A	N/A
Stall Current (A)		2.8	5.0										
Rated Power (kW)		0.63	1.13										
R (ph-ph) (Ohms)		4.49	1.49										
L (ph-ph) (mH)		10.7	4.73										

The information contained in this specification is for guidance only and does not form part of any contract.

N/A Not available

CT Dynamics Limited have an ongoing process of development and reserve the right to change the specification without notice.

Driving the world...

Control Techniques Drive & Application Centres

AUSTRALIA

Melbourne Application Centre
A.C.N. 003 815 281
Tel: 61 973 81777
Fax: 61 9729 3200
After Hours: 61 2 9963 5271

Sydney Drive Centre
A.C.N. 003 815 281
Tel: 61 2 9838 7222
Fax: 61 2 9838 7764
After Hours: 61 2 9963 5271

AUSTRIA

Linz Drive Centre
Tel: 43 7229 789480
Fax: 43 7229 7894810
After Hours: 43 7215 3502

BELGIUM

Brussels Drive Centre
Tel: 32 2725 2721
Fax: 32 2725 4940

CANADA

Toronto Drive Centre
Tel: 1 905 475 4699
Fax: 1 905 475 4694

CHINA

Shanghai Drive Centre
Tel: 86 21 5426 0668
Fax: 86 21 5426 0669
Beijing Application Centre
Tel: 86 10 6592 5321 ext. 20
Fax: 86 10 6590 3094

CZECH REPUBLIC

Brno Drive Centre
Tel: 420 541 192111
Fax: 420 541 192115
After Hours: 420 541 192119

DENMARK

Copenhagen Drive Centre
Tel: 45 4369 6100
Fax: 45 4369 6101
After Hours: 45 4369 6100

FINLAND

Helsinki Drive Centre
Tel: 358 985 2661
Fax: 358 985 26823
After Hours: 358 500 423271

FRANCE

Leroy Somer
Angoulême Drive Centre
Tel: 33 5 4564 5454
Fax: 33 5 4564 5400

GERMANY

Control Techniques GmbH
Meysstraße 20
D-53773 Hennef
Tel: 02242 877 0
Fax: 02242 877 277
After Hours: 0171 49 64 777

Control Techniques GmbH
Rodensteinstr. 19
D-64625 Bensheim
Tel: 06251 17 70 0
Fax: 06251 17 70 98
After Hours: 0171 49 64 777

Control Techniques GmbH
Rohrsdorfer Allee 14
D-09247 Chemnitz
Tel: 03722 5203 0
Fax: 03722 5203 30
After Hours: 0171 49 64 777

HOLLAND

Rotterdam Drive Centre
Tel: 31 1844 20555
Fax: 31 1844 20721
After Hours: 31 1844 20555

HONG KONG

Hong Kong Application Centre
Tel: 852 2979 5271
Fax: 852 2979 5220

HUNGARY

Budapest Drive Centre
Tel: 361 431 1160
Fax: 361 260 5483
After Hours: 36 309 77 2663

INDIA

Mumbai Application Centre
Tel: 91 20 613 1954
Fax: 91 20 612 3771

Kolkata Application Centre
Tel: 91 33 357 5302/357 5306
Fax: 91 33 357 3435
After Hours: 91 33 358 3622

Chennai Drive Centre
Tel: 91 44 496 1123/
496 1130/496 1083
Fax: 91 44 496 1602
After Hours: 91 44 496 1083

New Delhi Application Centre
Tel: 91 11 576 4782
Fax: 91 11 576 4782

IRELAND

Dublin Drive Centre
Tel: 353 45 448200
Fax: 353 45 433622

ITALY

Milan Drive Centre
Tel: 39 02575 751
Fax: 39 02575 12858
After Hours: 39 02575 751

Vicenza Drive Centre
Tel: 39 0444 396200
Fax: 39 0444 341317

KOREA

Seoul Application Centre
Tel: 82 2 557 7374
Fax: 82 2 557 7301
After Hours: 82 2 557 7374

MALAYSIA

Kuala Lumpur Drive Centre
Tel: 60 5634 9776
Fax: 60 5633 9592
After Hours: 60 12 333 835

NORWAY

Via Copenhagen
Drive Centre
Tel: 45 4369 6100
Fax: 45 4369 6101
After Hours: 45 4369 6100

REPUBLIC OF SOUTH AFRICA

Johannesburg Drive Centre
Tel: 27 11 462 1740
Fax: 27 11 462 1941
After Hours: 27 11 462 1740

RUSSIA

Moscow Application Centre
Tel: 7 095 232 9472
Fax: 7 095 956 4862

SINGAPORE

Singapore Drive Centre
Tel: 65 6468 8979
Fax: 65 6468 6982

SPAIN

Barcelona Drive Centre
Tel: 34 93 680 1661
Fax: 34 93 680 0903
/34 93 680 2823
After Hours: 34 610 554540

Bilbao Application Centre
Tel: 34 94 620 3646
Fax: 34 94 681 1406

Valencia Drive Centre
Tel: 34 96 154 2900
Fax: 34 96 153 2906

SWEDEN

Stockholm Application Centre
Tel: 46 8 554 24100
Fax: 46 8 554 24120

SWITZERLAND

Lausanne Application Centre
Tel: 41 21 637 7070
Fax: 41 21 637 7071

Zurich Drive Centre

Tel: 41 56 201 4242
Fax: 41 56 201 4243
After Hours: 41 79 357 8683

TAIWAN

Taipei Application Centre
Tel: 886 22325 9555
Fax: 886 22705 9131

THAILAND

Bangkok Drive Centre
Tel: 66 2580 7644
Fax: 66 2591 4559
A/Hours Sales: 66 1443 4095
A/Hours Service: 66 1443 4098

TURKEY

Istanbul Drive Centre
Tel: 90 216 418 2420
Fax: 90 216 418 2423
After Hours: 90 216 418 2420

UNITED KINGDOM

Telford Drive Centre
Tel: 44 1952 213700
Fax: 44 1952 213701
After Hours: 44 1952 213700

USA

Charlotte Application Centre
Tel: 1 704 393 3366
Fax: 1 704 393 0900
After Hours: 1 800 893 2321

Chicago Application Centre
Tel: 1 630 752 5249
Fax: 1 630 752 4156
After Hours: 1 800 893 2321

Cleveland Drive Centre
Tel: 1 440 717 0123
Fax: 1 440 717 0133
After Hours: 1 800 893 2321

Minneapolis Drive Centre
Tel: 1 952 995 8000
Fax: 1 952 995 8020
After Hours: 1 800 893 2321

● Drive & Application Centres
● Distributors

Providence Drive Centre
Tel: 1 401 333 3331
Fax: 1 401 333 6330
After Hours: 1 800 893 2321

Vietnam
Ho Chi Minh Application Centre
Tel: 84 8 842 5157
/84 8 849 1980
Fax: 84 8 842 5157

 **CONTROL
TECHNIQUES**
www.ctdynamics.com